

**PRECISE GRINDING
COMPLETE
REPROFILING.**



ROGRIND 13.45MD - 5159905901
ROBATTERY 71.02 - 7839900001

**For grinding welding joints and for reprofiling the complete rail head.
Can also be used in switches and for grinding grooved rails and crane rails.**

THE ADVANTAGES. YOUR BENEFITS.

Simple and practical.

- Choice between battery power or power pack
- Interchangeable guiding system for various applications
- Easy changing of cup wheel thanks to Quick Lock
- Non-projecting carrying handles allow for easy transport and easy storage
- LED lighting
- Ideal for use in tunnels and urban areas

Light-weight machine. Powerful grinding.

- The most powerful electric motor in its weight class for fast grinding
- No set-up time
- Rotational resistance can be adjusted at spindle hand wheel as required, without the use of any tools
- Grinding throughput: at least 60 minutes of continuous grinding (depending on rail profile, trimmer, grinding wheel etc.)

SPECIFICATION

Drive	BLDC electric motor
Output	6.6 kW
Weights	
Machine	from 40 kg
Battery 2300 Wh	17.5 kg
Power supply	18 kg
Copy roller spacing	850 mm
Dimensions (L x W x H)	1036 x 500 x 900 mm

INDIVIDUAL CONFIGURATION OPTIONS

1. Guiding systems

Rail guiding system
 Universal guiding system
 Grooved rail guiding system
 Crane rail machining set (up to rail head width 120 mm)
 Guiding system for small flat bottom rails

2. Guiding handle

Guiding handle left
 Guiding handle right

3. Carrying handles

Inside carrying handle
 Outside carrying handle
 Bow-type handle

4. Hand wheel

Hand wheel Ø 100 mm
 Hand wheel Ø 160 mm

5. Grinding spindle

Standard grinding spindle
 Raised grinding spindle

6. Foldable spark protection

ACCESSORIES

Multi-Drive-Technologie

7839900001 Battery 2300 Wh
 7879900001 Charger for battery 2300 Wh
 5039900003 Power supply 400 Volt
 9000208017 Battery box for battery 2300 Wh

Accessories grinding machine

5158930001 Multiroller carrier (2 required)
 5158931002 Extension arm for frog noses
 5158930014 Crane lifting eye

Cup wheels

9878081000 Ø 90 mm conical for frog noses and switches,
 central nut holder M20 (also suitable for the running
 surface of grooved rails)
 9002000330 Ø 90 mm cylindrical for built-up welds,
 central nut holder M20
 9002000687 Ø 125 mm central nut holder M20
 9002000688 Ø 125 mm screw fastening 4xM8, pitch circle Ø 90 mm
 Other cup wheels on request.
 9000200182 Steel wire brush
 e.g. for removing rust from rails
 (not to be used without centring nut)
 8931002007 Centring nut, fixings for steel wire brush

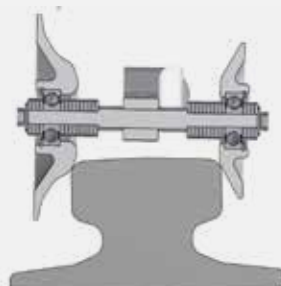

5158930001



7839900001



5039900003

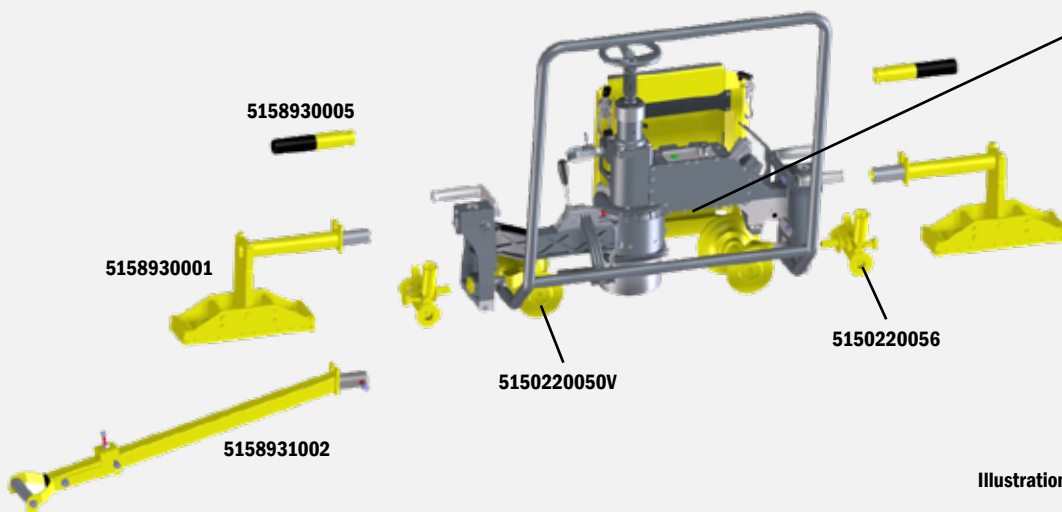

5158930005

5158930001

5158931002

5150220050V

5150220056

Illustration 13.45MD - Right-hand design

**Do you require a different design?
 Please get in touch with your ROBEL contact.**